



WEEE RoHS CE FC



**HM-K19**  
MORTISE BOLT LOCK



**HM-K29**  
SURFACE BOLT LOCK

## ELECTRIC BOLT LOCK

### HM-K19 MORTISE BOLT LOCK HM-K29 SURFACE BOLT LOCK

- The world's 1st innovative and the best electric bolt lock, is created by Hwan Ming Enterprise Co., Ltd.
- Two types of lock : mortise bolt lock and surface bolt lock.
- Innovation design. Easy to install. To minimize the installation danger and difficulties.
- Innovation design. The voltage of the new device is only 12VDC 160~180mA (operating), it is better than the other bolt lock 12VDC 800~900mA (operating) version. The new design only uses one 1Amp power supply with other bolt locks, card readers and sensors altogether.
- This product has already had patents applied for in nine countries: China(ZL2009 201 55990.0), Japan (Patent No.: 3153242), Korea, UK, France, Germany (Patent No.: Nr.20 2009 008 357.8), Italy, USA and Taiwan (Patent No.: M362876). Copy prohibited.

### Electric Bolt Lock



# ELECTRIC BOLT LOCK

## HM-K19 MORTISE BOLT LOCK

## HM-K29 SURFACE BOLT LOCK

Electronic Specification	
Mortise bolt lock & Surface bolt lock	Power to lock
Power source	12VDC±10%
Current consumption	180mA(MAX)
Lock delay setting	2.5 ~ 5 seconds setting available
Unlock Dry Contact	Grey:COM Purple:NC White:NO (110VAC/1A, 24VDC/2A)
Lock Dry Contact	Grey:COM Purple:NO White:NC (110VAC/1A, 24VDC/2A)
Position Installation	on top of the door / side of the door
Door Detection	NC:01A/30VDC Green:COM Blue:NC
Operating Temperature	-10°C ~ 50°C
Weight	330g (Mortise bolt lock) 512g (Surface bolt lock)

### Dimension

**HM-K19**  
MORTISE BOLT LOCK

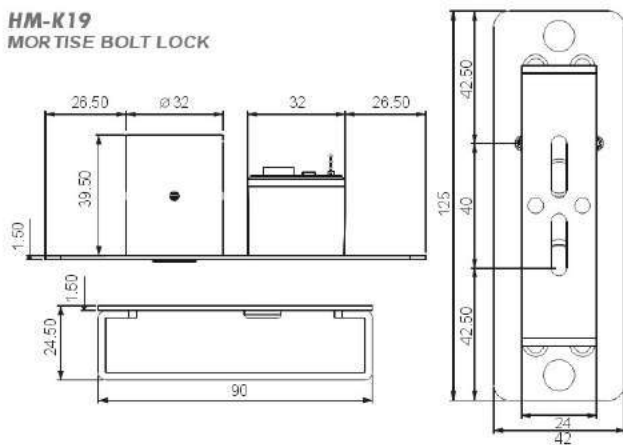

**HM-K29**  
SURFACE BOLT LOCK

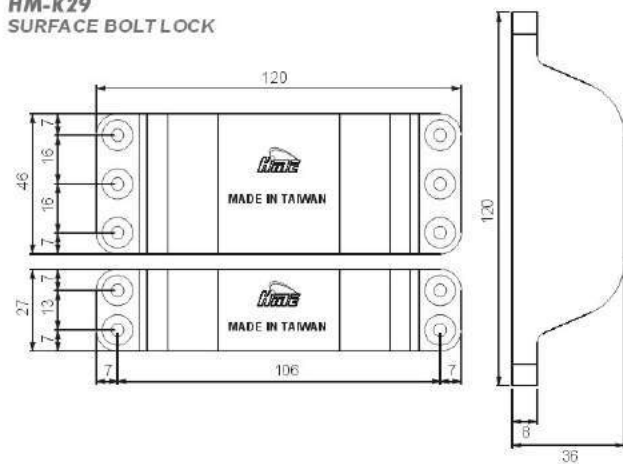

### Product Features:

1. The bolt of this lock is so strong design and the switch is located correctly. It can withstand an extremely strong impact without any deformation.
2. Both mortise and surface bolt lock can be installed at 90° and 180°.
3. Only simple tools are needed to install the mortise bolt lock: auto punch, power drills, (3mm, 6mm, 34mm) drills, and screwdrivers.
4. Only simple tools are needed to install the surface bolt lock: power drills and screwdrivers.
5. Current voltage: operating and standby voltage consumption is 12VDC / the current consumption is only 180mA (Max).
6. The electric bolt lock uses the same power supply with any other locks, sensors and card readers altogether. It will be compatible with any other brand of sensors and card readers.
7. These devices have been tested more than 500,000 times. Precision, durability and reliability.
8. HM-K19 Mortise Bolt Lock Accessories: Glass Fixture(10mm)  
HM-K29 Surface Bolt Lock Accessories: Mounting bracket

### Illustration of Installation

**HM-K19**  
MORTISE BOLT LOCK

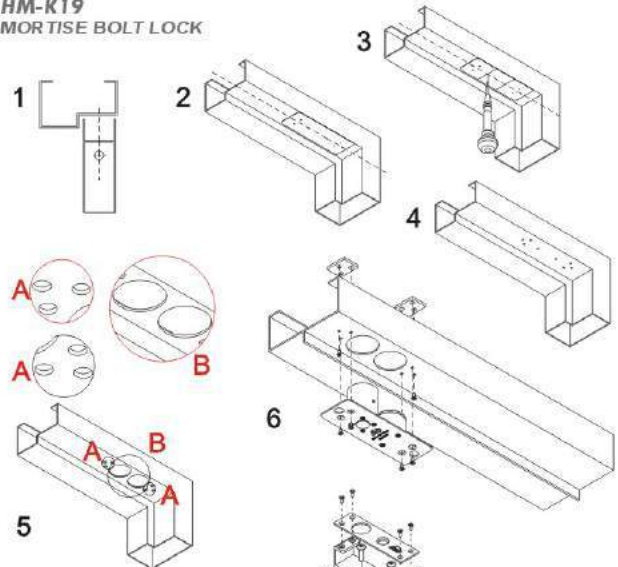

**HM-K29**  
SURFACE BOLT LOCK

